

FACTORYCAT[®]

Industrial Cleaning Equipment

MICRO-HID

17" - 26" Scrubbers



A COMPLETE FAMILY OF INDUSTRIAL CLEANING EQUIPMENT



KEY FEATURES

INDUSTRIES



Machine Control Panel uses off-the-shelf toggle and marine duty switches and features universal icons which simplifies training.



Vacuum Muffler allows machine to consistently achieve industry low sound levels for noise sensitive applications while thoroughly drying the floor.



Squeegee Adjustments made simple with quick change squeegee latch allows toolless maintenance and 4-sided squeegee blade.

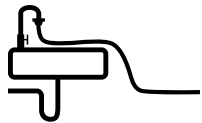

Front Fill System features a retractable hose for easy filling on standard sink-faucets and a stainless screen for bucket filling.

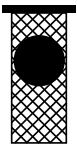

Oversized Vacuum Screen Shut-Off quickly arrests overflow issues to protect the Vacuum Motor.

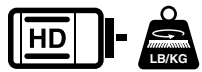

High Performance motors and down pressure provides an unmatched standard of cleaning.



- Fabrication Shops
- Machine Shops
- Aviation
- Beverage Distribution
- Warehouses
- Automotive Shops
- Food Packaging
- Sports Arenas

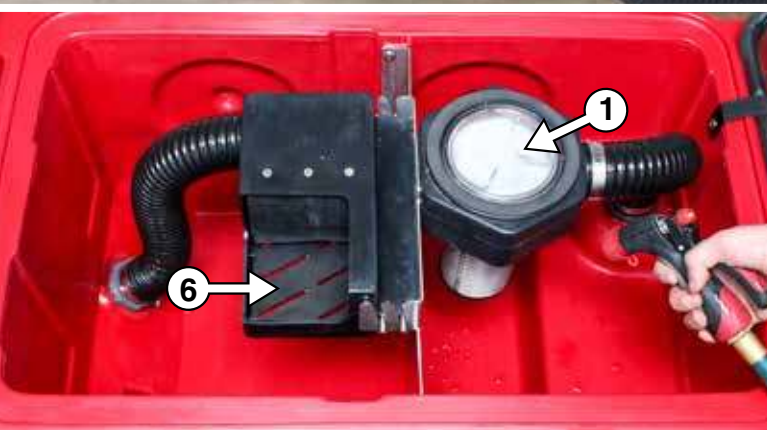

TANK TIPS FOR ACCESS

- 1 Vacuum Screen & Filter Cleaning
- 2 Service Batteries
- 3 Inspect Scrub Motors
- 4 Inspect Vacuum Motor
- 5 Inline Solution Filter
- 6 Drain Saver

Reduce costly repairs associated with clogged floor drains with our Drain Saver Basket.



VIEW INSIDE

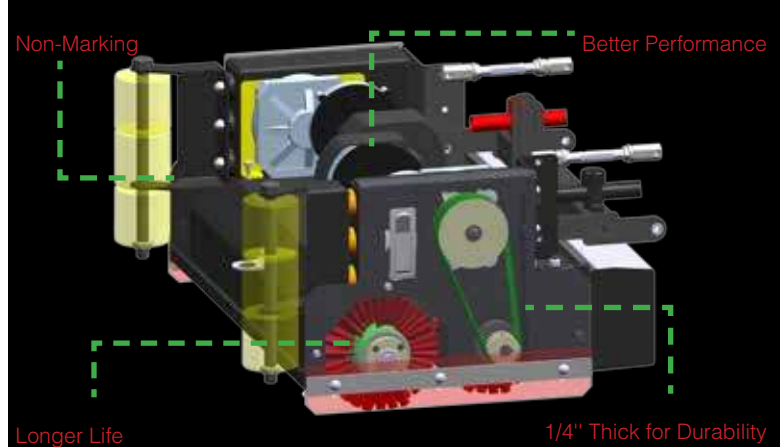
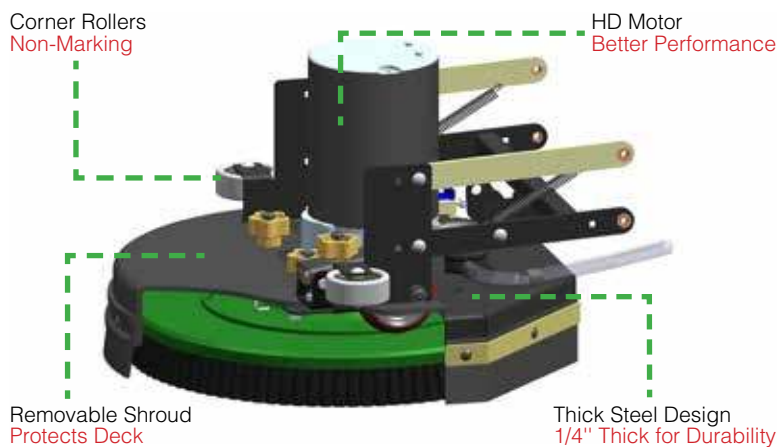
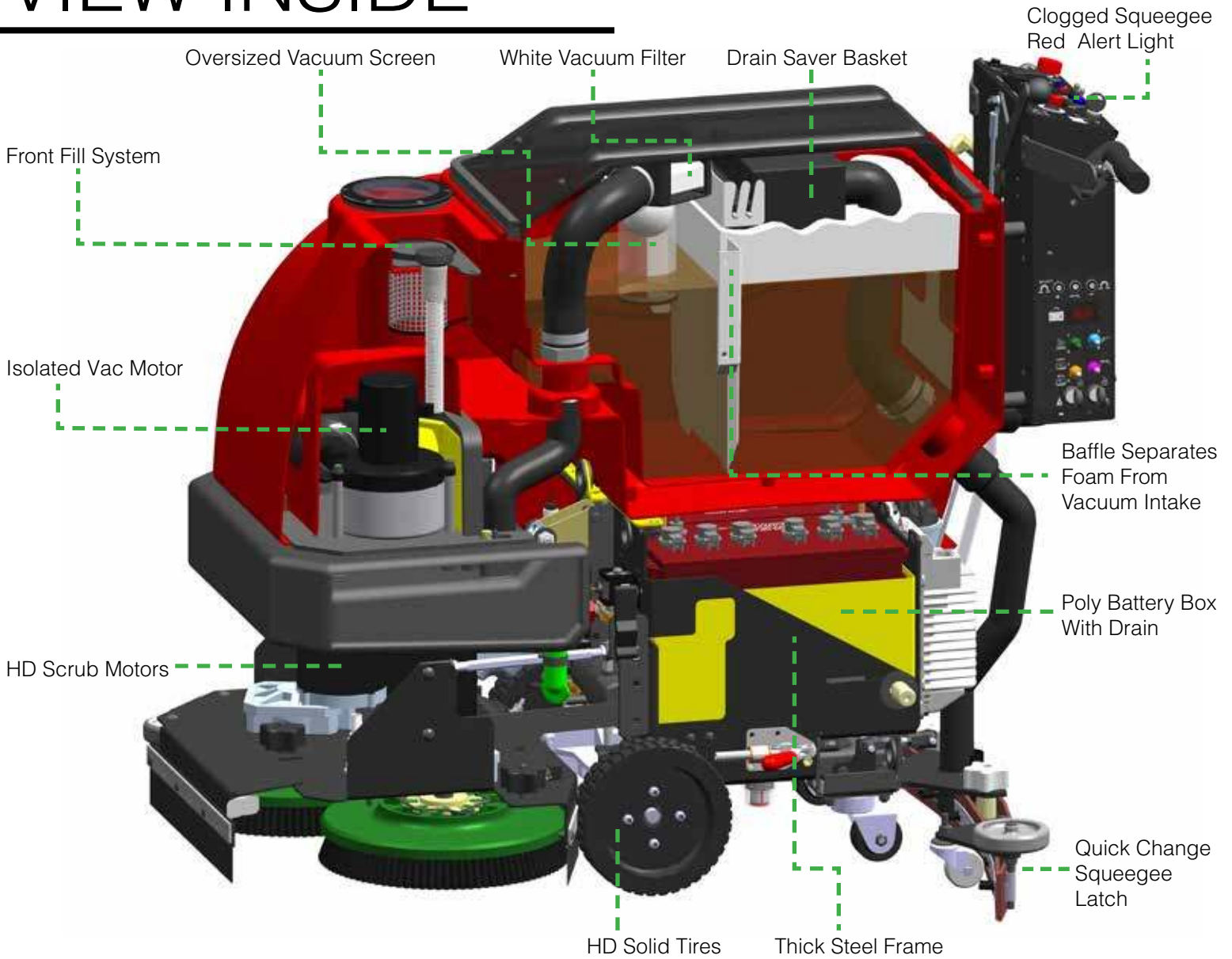

Disk Benefits

- Brush / Pad Selection
- Lowest Maintenance Cost
- Gimballed Drivers Improves Cleaning On Irregular Floors
- Brushes Individually Driven For Unmatched Performance

CALL FOR A DEMONSTRATION



☎ **800-634-4060**
 🌐 **(+001)-262-681-3583**
 🌐 **www.factorycat.com**

Since 1986, our family owned company has been designing, building and supporting the best in floor maintenance equipment. Our **FACTORYCAT** brand services the world with unsurpassed industrial cleaning equipment, continually exceeding expectations and setting the industry bar that much higher.

We've built our reputation by providing the highest value machines and providing local support via 425 distributors in over 42 different countries.

AUTHORIZED DISTRIBUTOR

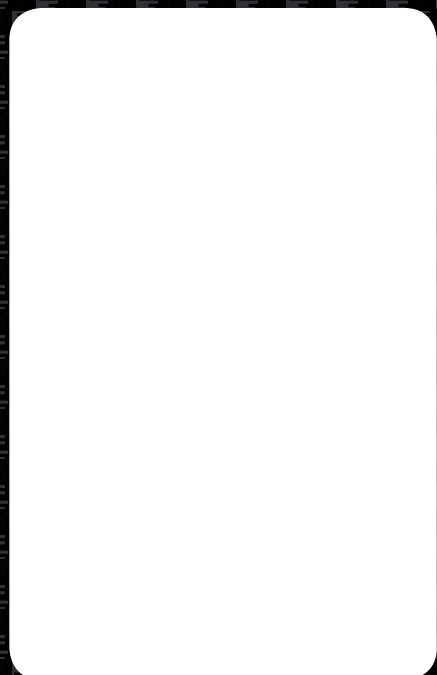

Tank Material:	Poly 5/16" (7.9 mm) (4.8 mm)
Front Wheels (Diameter x Width):	(2x) 8" x 2" ([2x] 20.3 x 5.1 cm) - Solid Black ([2x] 6.4 x 3.5 cm)
Size (L x W x H):	45" x 21" x 39" (114.3 x 53.3 x 99.1 cm) (126 - 149 kg)
Weight (w/ 130 ah Batteries):	410 - 460 lbs (186 - 209 kg)
Disk Dimensions: <small>Includes Shroud with Rollers for Wall Protection</small>	17" - (1x) 17" Diameter (43.2 - [1x] 43.2 cm) 20" - (1x) 20" Diameter (50.8 - [1x] 50.8 cm) 26" - (2x) 13" Diameter (66.1 - [1x] 33 cm) (43.2 & 50.8 cm [1x] 559 watts) (66.1 cm [2x] 559 watts)
Disk Brush Speed:	200 rpm or 270 rpm (63.5 - [2x] 15.2 x 58.4 cm)
Cylindrical Motor:	(2x) 0.75 hp / 350 rpm ([2x] 559 watts)
Brush Pressure Settings:	(5) with Auto Adjust (57 kg) (227 kg)
System Voltage:	24 VDC
Optional Battery: <small>*Includes Onboard Charger</small>	150 ah WET / 115 ah AGM* / 140 ah AGM*
Charger:	120VAC / 60 Hz Input - 24VDC / 12 amp Output
Power:	0.75hp - All Gear / Sealed (559 watts) (0 - 70 m/min / 4 km/h)
Scrubbing Speed:	0 - 184 ft/min / 2 mph (0 - 56 m/min / 3 km/h) (0 - 40 m/min / 2 km/h)
Solution Tank Capacity:	13 Gallons (49.2 liters) - w/ Graduated Site Tube (0 - 1.9 LPM)
Recovery Tank Capacity:	15 Gallons (56.8 liters) - 1.5" diameter Drain Hose (4.7 liters)
Drain Saver:	30 cubic inches (492 cubic cm) (640 watts)
Vacuum Specs (Water Lift / Airflow):	70" / 70 cfm (178 cm / 2 cm/m) (83.8 cm) (91.4 cm)
Cleaning Width:	17", 20" & 26" - Disk (43.2, 50.8 & 66.1 cm) 25" - Cylindrical (63.5 cm)
Productivity - Theoretical: <small>****Productivity is based off of ISSA 2010 Cleaning Times</small>	Up to 27,027 sqft (2,511 sqm)**** (1,164 sqm)

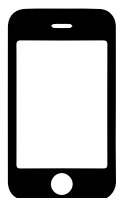

Manufactured By:
 R.P.S. Corporation
 1711 South Street
 Racine, Wisconsin 53404 (USA)
 Phone: (800) 634-4060
 International: (+001) 262-681-3583
 www.factorycat.com